



### **[www.kaufmannhardware.co.za](http://www.kaufmannhardware.co.za)**

Kaufmann products are exclusively manufactured for and distributed by Agrinet (Pty) Ltd.  
Private Bag x165, Centurion, 0046  
T: +27(0) 12 657 2222  
E: [enquiries@agrinet.co.za](mailto:enquiries@agrinet.co.za)



**Warranty Information:** Kaufmann products have a limited warranty against defects in material and workmanship from the date of purchase. Kaufmann products have been designed for domestic/light industrial use. The warranty does not apply to defects resulting from accidental damage, improper use or exceeding the design limits of the product.

For full terms & conditions, please visit [www.kaufmannhardware.co.za](http://www.kaufmannhardware.co.za).



# KAUFMANN

## FOUNTAIN PUMP KIT

**FP38**  
**FP50**  
**FP85**  
**FP120**



Always Read Instruction Manual  
Retain for Future Reference

## INTRODUCTION

Thank you for selecting the Kaufmann fountain pump. Before using this pump please take a moment to review this manual.

To avoid an accident do not use the pump in any way other than as described in this manual. Please note the manufacturer cannot be responsible for accidents arising because the product was not used as prescribed. After reading this manual keep it as a reference in case questions arise during use.

## WARRANTY

Kaufmann products have a limited 3 years warranty against defects in material and workmanship from the date of purchase. Kaufmann products have been designed for domestic/light industrial use.

The warranty does not apply to defects resulting from accidental damage, improper use or exceeding the design limits of the product.

For full terms & conditions, please visit [www.kaufmannhardware.co.za](http://www.kaufmannhardware.co.za).

## PRIOR TO OPERATION AND INSTALLATION

When the pump is delivered, first perform the following checks:

Check for any damage to pump and power cable that may have occurred during the shipment.

Check the model number to make sure it is the correct product and verify the voltage and frequency are correct.

## CAUTION

DO NOT operate this product under any condition other than those for which it is specified. Failure to observe this precaution can lead to electrical shock, electrical leakage, fire, water leakage or other problems.

The pump is a 230 volt 50 Hz pump, please only use with a power supply voltage within 230-240 volt 50 Hz.

Never place your hand or any object in or near the inlet opening while this equipment is operating. If pump inlet is clogged, always turn off the power supply and wait until the motor is completely stopped before attempting to remove any clogged material.

Please make sure that the power plug and the AC outlet receptacle are protected and away from water or pump discharge hose to prevent accidental electric shock or short circuit.

Always operate the pump completely submerged in water.

Avoid dry operation, which will not only lower performance but can cause the pump to overheat/malfunction, leading to electrical leakage, shock or premature failure.

Always turn off power or unplug the pump prior to performing any maintenance or placing your hands into the water.

## CAUTION

This pump is to be used in a circuit protected by a ground circuit interrupter.

## WARNING

**Risk of electric shock!** This pump is supplied with a grounding conductor and grounding type attachment plug. To reduce the risk of electric shock, be certain that it is connected only to a properly grounded, grounding type receptacle.

## ELECTRICAL SAFETY

Electrical wiring should be installed by a qualified electrician in accordance with all applicable safety regulations. Incorrect wiring can lead to a pump malfunction, electrical shock or fire.

Pumps should operate on a designated, 230-240V circuit.

Pump must be protected by a ground fault circuit interrupter (GFCI).

Pump must be plugged into a standard, properly grounded, three pronged outlet.

**Warning!** If the power cord or plug is damaged, do not use the pump. The power cord or plug may only be repaired by a certified electrician.

## SAFETY INSTRUCTIONS

**Attention!** Make sure the pump works at a proper water level. Do not operate the pump without water. If so, the pump should be turned off immediately.

Do not lift, lower or handle the pump by pulling on the electrical cord. Make sure the electrical cable does not become excessively bent or twisted and does not rub against a structure in a way that might damage it.

Always disconnect the power supply before doing any maintenance or placing your hands into the water to which this pump is immersed.

The submersible pump should not be used if the electrical supply cable is damaged in any way. If a cable with damaged insulation is submerged in water, there is danger of water seeping into the pump motor and causing a short. The electrical cable cannot be replaced. If the cord is damaged, the pump should be discarded. Altering the electrical cable in any way will void the warranty.

Access by children should also be prevented with appropriate measures.

Circulation of caustic fluids, as well as the circulation of abrasive materials, must be avoided at all costs.

The pump must not be used to pump salt water, sewage, ammable or corrosive liquids, greases, oils or food waste.

Pay careful attention to the water level while the pump is operating. The pump must be fully submersed at all times of operation.

Repeating cycles of stopping and restarting will damage the water pump. Do not continue operation at low water level or while the inlet is clogged with debris. Not only will performance suffer, but also such conditions may cause noise, heavy vibration, and pump failure.

In case of excessive vibration, unusual noise or odor, turn off the power immediately and consult your nearest authorised service centre.

### ASSEMBLY

The pump is designed to be used in aquariums/water features.

Insert the suction cups into the bottom of the motor body and then install the pump under the water surface.

The pump must be placed on the bottom of the aquarium/water feature. To ensure that the pump works properly, keep the bottom of the aquarium/ water feature free from sludge and dirt of all kinds.

For proper cooling, only operate pump when it is completely submerged.

### OPERATION

Kaufmann pumps are for use in water only. Water temperature should never exceed 95° F (35° C).

Set the pump on a level spot in the aquarium/water feature. The suction cups must be in contact with the aquarium/fountain floor or a smooth platform.

**Note:** Do not plug in pump yet.

**Caution:** Verify pump is adequately supported. If you use an additional hose and in-line filter (not included), do not use it or the connecting tube to support the pump.

Once the pump is fully submerged and adequately supported you can adjust the flow rate with the control valve.

**Note:** After reading these instructions, consider the following points before starting the pump:

Verify that the pump rests on the floor of the shaft, and it is not suspended by the power cord.

Verify that the delivery pipe is properly connected.

Verify that the electrical connection is 230 V-50 Hz.

Verify that the electrical socket is in good condition.

Verify that water and moisture cannot get near the power supply socket.

Verify that the pump is installed so as to prevent running dry.

Once you've verified that the pump has a proper setup, dry your hands and plug the power cord into the electrical outlet to begin pump operation.

### MAINTENANCE AND INSPECTION

**Warning!** To prevent serious injury from accidental operation: Unplug the Pump from its electrical outlet before performing any inspection, maintenance, or cleaning procedures.

Regular maintenance and inspections are a necessity for continued efficient functioning. If any abnormal conditions are noticed, refer to the section on Troubleshooting and take corrective measures immediately.

If the pump is moved to a different aquarium or water feature, flush it out with clean water and dry before setting up in new water feature.

If cord is damaged, it must be replaced by a qualified technician.

### MONTHLY INSPECTION

Check for any drop in performance. Reduced performance is usually caused by debris blocking the pump intake.

Detach the power cable from the receptacle or turn off the power supply (circuit breaker).

Disconnect the pump discharge and remove the pump from the water.

Remove any accumulated debris from the surface of the pump and pre-filter.

Remove the impeller chamber from the motor body and take out the impeller and shaft.

Inspect the impeller. The impeller should spin freely. If the impeller feels tight or gritty when spun, please refer to the cleaning instructions on page 4.

### WINTER MONTHS

Under no circumstances should the pump be left in frozen water.

When the pump is out of use for an extended period, wash it and dry it thoroughly, then store it indoors.

**Note:** Always run a test operation before putting the pump back into operation. When the pump is left installed in water it should be run at regular intervals (about once per week).

## CLEANING

Fountain pumps will require periodic cleaning of the impeller and impeller chamber. Please follow the directions below for proper cleaning procedures:

Remove the impeller chamber from the motor body and take out the impeller and shaft.

Inspect the impeller and the impeller chamber for built up debris.

Loose debris can be flushed out with clean water. Often in hard water, well water or pond-

free applications, debris may appear as a crusty film around the impeller and in the impeller chamber. Remove this film using a scrub brush and white vinegar.

Inspect the intake O-ring for nicks or breaks.

To prevent damage, do not rest the pump on the impeller or pry against the impeller.

Once, clean reassemble Pump.

**Note:** Make sure the power cord is unplugged before performing any maintenance or cleaning.

## PARTS LIST 1

MODEL: FP38 & FP50

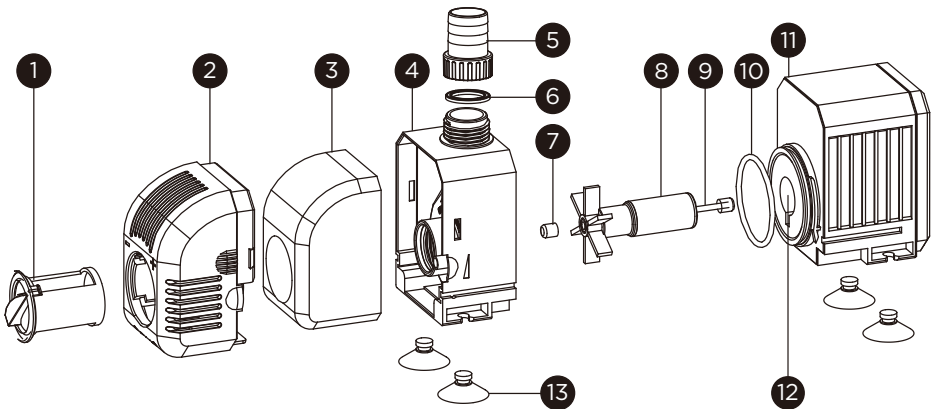

1. Flow adjuster
2. Pre filter
3. Filter sponge
4. Pump housing
5. Outlet
6. Gasket
7. Bearing

8. Impeller
9. Impeller axle
10. O-ring
11. Motor body
12. Impeller chamber
13. Suction cups

## PARTS LIST 2

MODEL: FP80 & FP120

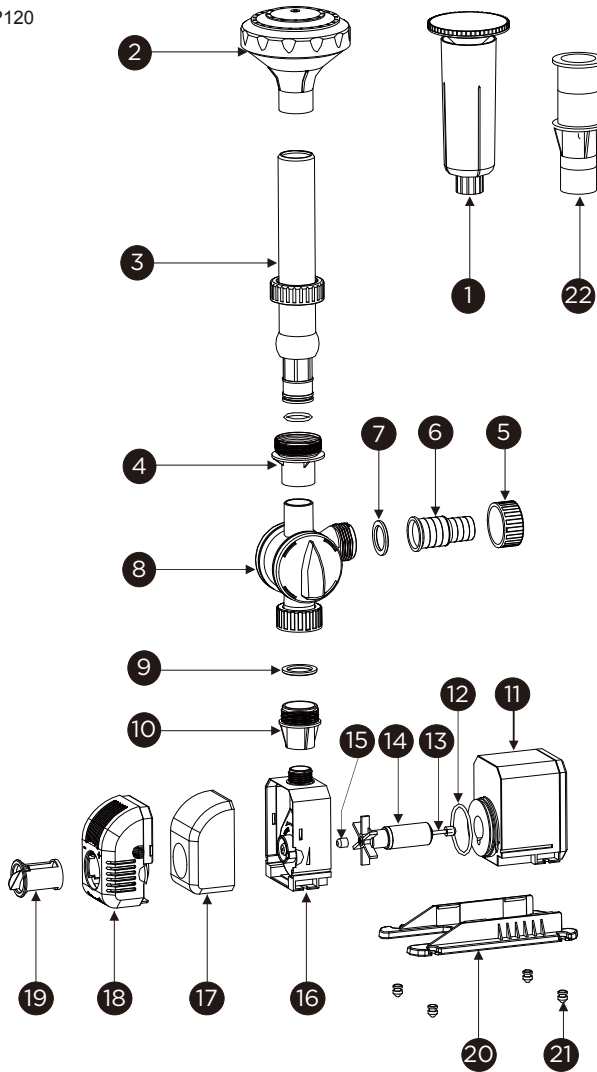

- |                         |  |
|-------------------------|--|
| 1. Waterbell head       | 12. O-ring                                   |
| 2. Volcano head         | 13. Impeller axle                            |
| 3. Flexible pipe        | 14. Impeller                                 |
| 4. Connecting flange    | 15. Bearing                                  |
| 5. Outlet nut           | 16. Pump housing                             |
| 6. Outlet               | 17. Filter sponge                            |
| 7. Gasket               | 18. Pre filter                               |
| 8. Adjuster             | 19. Flow adjuster                            |
| 9. Gasket               | 20. Stand                                    |
| 10. Connecting flange 2 | 21. Suction cups                             |
| 11. Motor body          | 22. Fountain head (FP85 & FP120 Models Only) |

**TROUBLESHOOTING**

Always turn off power before inspecting the pump. Failure to observe this precaution can result in a serious accident.

Before ordering repairs, carefully read through this instruction manual. If the problem persists, contact your dealer.

<b>Problem</b>	<b>Possible Cause</b>	<b>Possible Solution</b>
Pump does not run	Power is off	Turn power on
	Power failure	Check power supply or contact local electric company.
	Power cord is not connected	Connect power cord
	Impeller is stuck	Remove debris/clean impeller
Pump stops after starting	Pump is overheating	Submerge pump/Raise water level/ Allow pump to cool/Clean impeller
	Power/Current overload	Check length/size of power cable. Check or replace GFI
	Intake is blocked/ Impeller needs cleaning	Remove debris from the impeller chamber. Refer to page 4 for cleaning instructions.
Diminished flow rate or no water flow	Impeller needs cleaning	Refer to page 4 for cleaning instructions
	Obstruction in pump or piping obstruction	Clear obstruction
	Low water level	Stop operation/Raise water level
	Air-lock in the impeller chamber	Place pump in water. Turn the pump On/Off intermittently 2 or 3 times

**TECHNICAL SPECIFICATION**

Model Number	FP38
Operating Voltage	230V/50Hz
Power Consumption	35W
Maximum Pump Height	2m
Maximum Flow Delivery	1 000l/h
Cable Length	10m
Dimensions	160 x 90 x 615mm
Weight	2.06 kg

Model Number	FP50
Operating Voltage	230V/50Hz
Power Consumption	55W
Maximum Pump Height	3m
Maximum Flow Delivery	2000l/h
Cable Length	10m
Dimensions	180 x 100 x 620mm
Weight	2.46 kg

Model Number	FP85
Operating Voltage	230V/50Hz
Power Consumption	80W
Maximum Pump Height	3.8m
Maximum Flow Delivery	4000l/h
Cable Length	10m
Dimensions	210 x 120 x 640mm
Weight	3.2 kg

Model Number	FP120
Operating Voltage	230V/50Hz
Power Consumption	100W
Maximum Pump Height	4m
Maximum Flow Delivery	4600l/h
Cable Length	10m
Dimensions	210 x 120 x 640mm
Weight	3.55 kg